



The 1630 Series is the most popular built-in lock for lockers with gravity lift handles; it offers high security and convenient automatic locking.

1630 SERIES

Exclusive Features

- Vertical travel locking bolt engages lift handle locker mechanism
- Convenient, automatic locking
- Fits all lift handle lockers

Built-in Combination Lock Advantages

- Concealed mounting and rugged steel case deter vandalism
- Secure, three digit combination is easy to dial
- Longer useful life with five different combinations - easily changed with the touch of a button, which maintains security for new students or employees
- Standard key control allows quick supervisory access
- End user registration and control charts provided to secure and simplify administration
- Model 1631 is available for left-handed doors



1630 locked.



1630 unlocked.

SPECIFICATIONS

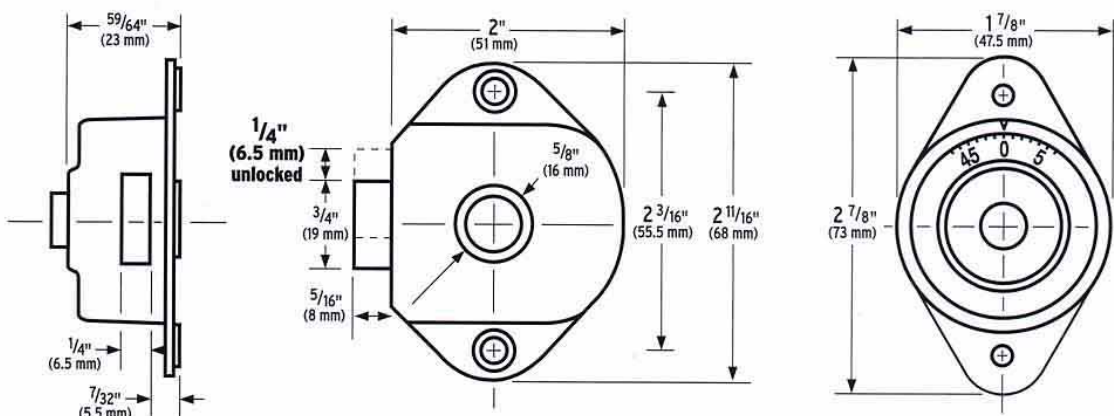

1630 shown. Required door thickness 0.03 - 0.125 in. (0.8 - 3.2 mm)